

# OX/OY Series

## Ceramic Composition 10% Tolerance

The OX/OY Series of fixed ceramic resistors are ideal for circuitry associated with surges, high peak power or high energy. They offer enhanced performance in high voltage power supplies, R-C snubber circuits, and inrush limiters. The OX/OY resistors can often replace carbon composition resistors which can be difficult to source.



### FEATURES

- Replaces 1 and 2 watt carbon composition resistors
- Meets high energy density demands
- High peak power
- 10% Tolerance

### SERIES SPECIFICATIONS

Series	Watts max.*	Resistance range	Joules max.**	Max. working volts
OX	1	3.3Ω-100K	50	300
OY	2	3.3Ω-1M	80	400

\* at 70°C. \*\*For a single impulse.

### CHARACTERISTICS

<b>Terminals</b>	Pb-free solder-coated axial	
<b>Coating</b>	Silicone ceramic	
<b>Derating</b>	Linear from 100% @ +70°C to 0% @ +200°C	
<b>Operating Temp. Range</b>	-40°C to +220°C	
<b>Tolerance</b>	±10% standard	
<b>Power Rating</b>	Based on 70°C free air rating	
<b>Temperature Coefficient</b>	-1300 ±300ppm/°C.	

	OX	OY
<b>Max Working Voltage</b>	300V	400V
<b>Dielectric Strength</b>	500V	700V
<b>Max Overload Voltage</b>	600V	800V
<b>Max Pulse Voltage<sup>1</sup></b>	14KV	20KV
<b>Pulse Tolerance, 100 pulses</b>	1240V @ 52μF, 40J/ 35 sec.	1640V @ 52μF, 70J/35 sec.

<sup>1</sup>See figures

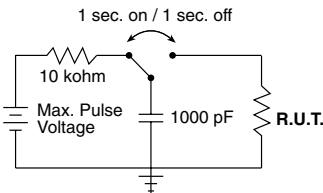

14KV and 20KV values used in circuit as shown; full voltage not applied directly to resistor.

Test	Condition	Maximum ΔR
<b>Life Test</b>	MIL-STD-202, Method 108	±5%
<b>Short Time Overload</b>	2x rated V, 5 sec ON @ 70°C	±(2% +0.05Ω)
<b>Resistance to Pulse<sup>1</sup></b>	20,000 cycles. See circuit for test conditions	±5%
<b>Thermal Shock</b>	MIL-STD-202, Method 107	±(2% ±0.05Ω)
<b>Moisture Resistance</b>	1000 hrs @ 40°C, 90 - 95% RH	±5%

### Resistance to Pulse

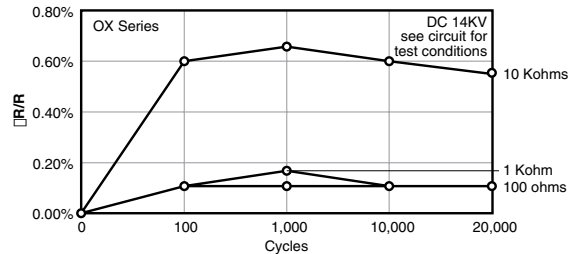
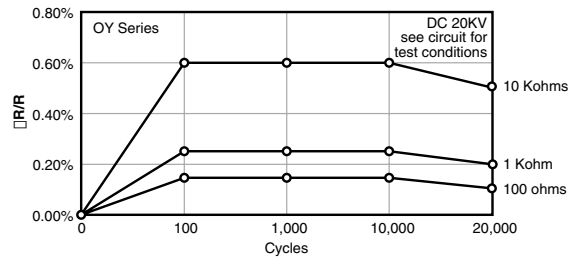

(continued)

# OX/OY Series

Ceramic Composition  
10% Tolerance

## DIMENSIONS

in./mm

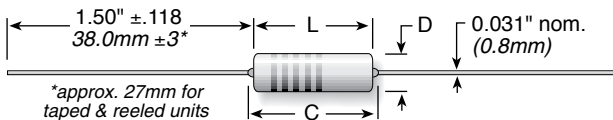

Series	Length L ±.039 (±1.0)	Length C max.	Diameter D ±.039 (±1.0)	Qty. per reel
OX	0.65 / 16.5	0.748 / 19.0	0.217 / 5.5	1000
OY	0.748 / 19.0	0.886 / 22.5	0.276 / 7.0	500

## Tape and Reel Dimensions

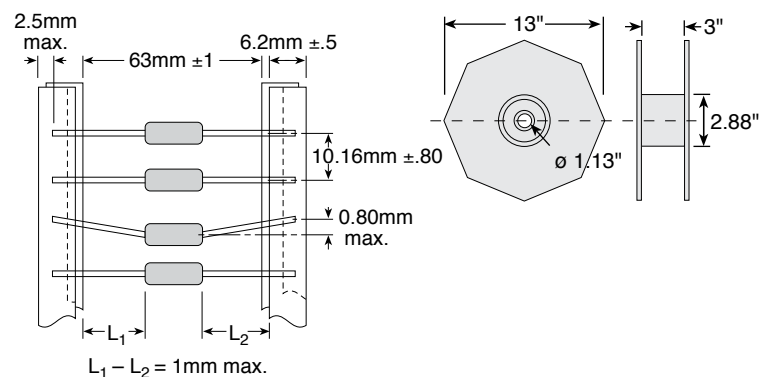

## ORDERING INFORMATION

### Standard part numbers for OX/OY Series

Ohmic value	Part No. Prefix Suffix	Wattage 1 2	Ohmic value	Part No. Prefix Suffix	Wattage 1 2	Ohmic value	Part No. Prefix Suffix	Wattage 1 2	Ohmic value	Part No. Prefix Suffix	Wattage 1 2	Ohmic value	Part No. Prefix Suffix	Wattage 1 2
3.3	-33GKE	✓ ✓	27	-270KE	✓ ✓	220	-221KE	✓ ✓	1800	-182KE	✓ ✓	15000	-153KE	✓ ✓
3.9	-39GKE	✓ ✓	33	-330KE	✓ ✓	270	-271KE	✓ ✓	2200	-222KE	✓ ✓	18000	-183KE	✓ ✓
4.7	-47GKE	✓ ✓	39	-390KE	✓ ✓	330	-331KE	✓ ✓	2700	-272KE	✓ ✓	22000	-223KE	✓ ✓
5.6	-56GKE	✓ ✓	47	-470KE	✓ ✓	390	-391KE	✓ ✓	3300	-332KE	✓ ✓	27000	-273KE	✓ ✓
6.8	-68GKE	✓ ✓	56	-560KE	✓ ✓	470	-471KE	✓ ✓	3900	-392KE	✓ ✓	33000	-333KE	✓ ✓
8.2	-82GKE	✓ ✓	68	-680KE	✓ ✓	560	-561KE	✓ ✓	4700	-472KE	✓ ✓	39000	-393KE	✓ ✓
10	-100KE	✓ ✓	82	-820KE	✓ ✓	680	-681KE	✓ ✓	5600	-562KE	✓ ✓	47000	-473KE	✓ ✓
12	-120KE	✓ ✓	100	-101KE	✓ ✓	820	-821KE	✓ ✓	6800	-682KE	✓ ✓	56000	-563KE	✓ ✓
15	-150KE	✓ ✓	120	-121KE	✓ ✓	1000	-102KE	✓ ✓	8200	-822KE	✓ ✓	68000	-683KE	✓ ✓
18	-180KE	✓ ✓	150	-151KE	✓ ✓	1200	-122KE	✓ ✓	10000	-103KE	✓ ✓	82000	-823KE	✓ ✓
22	-220KE	✓ ✓	180	-181KE	✓ ✓	1500	-152KE	✓ ✓	12000	-123KE	✓ ✓	100000	-104KE	✓ ✓
														1 MEG -105KE ✓ ✓

